

AWARD OF CONTRACT TO JORGE FLORES
IFB No. S-1093-A WALK IN REFRIGERATOR/FREEZER
August 28, 2012
Page 2

and references of the contractor have been reviewed and verified by staff, and all other documentation is in order. The bid results are as follows:

BIDDER NAME	BASE BID	OPTION A	OPTION B	TOTAL BID AMOUNT
Jorge Flores	\$38,855.00	\$375.00	\$1,150.00	\$40,380.00
Gilmore Refrigeration, Inc.	\$58,000.00	\$450.00	\$600.00	\$59,050.00
California Industrial Refrigeration Machine, Inc.	\$64,950.00	\$500.00	\$2,500.00	\$67,950.00
A&H Refrigeration, Inc.	\$78,500.00	\$0.00	\$0.00	\$78,500.00

FINANCIAL IMPACT

Using Prop. 69 money creates no burden on the City's General Fund. This freezer project is specifically outlined in the allocation of the Prop. 69 funds.

The County of Orange issued a check to the City in the amount of \$104,701 on March 4th, 2011. These funds were encumbered by the City Council at the March 8th, 2011, City Council meeting.

The Police Department is required to submit proof of purchase for the items identified above.

RECOMMENDATIONS

It is recommended that the City Council:

- Award a contract to Jorge Flores in the amount of \$40,380 for the walk-in refrigerator/freezer project; and
- Authorize the City Manager to execute the agreement and make minor modifications as appropriate on behalf of the City.



KEVIN RANEY
Police Chief



By: Ted Peaslee
Lieutenant

Attachment - Agreement

Recommended for Approval



Matthew Fertal
City Manager

SECTION 4 - AGREEMENT**PROJECT AGREEMENT**

THIS AGREEMENT is made this ____ day of _____, 2012 by the CITY OF GARDEN GROVE, a municipal corporation, ("CITY"), and **Jorge Flores, a sole proprietor**, hereinafter referred to as ("CONTRACTOR").

RECITALS:

The following recitals are a substantive part of this Agreement:

This Agreement is entered into pursuant to Garden Grove COUNCIL AUTHORIZATION, DATED _____.

CITY desires to utilize the services Furnish, Deliver, and Install a Walk-In Refrigerator/Freezer at the Garden Grove Public Safety Building located at 11301 Acacia Parkway, Garden Grove, CA.

CONTRACTOR is qualified by virtue of experience, training, education, and expertise to accomplish services.

AGREEMENT

THE PARTIES MUTUALLY AGREE AS FOLLOWS:

- 4.0 **Compensation.** CONTRACTOR shall be compensated as follows:
Compensation under this agreement shall be a firm fixed amount of amount of Forty Thousand Three Hundred Eighty dollars (\$40,380.00), which includes the bid amount of \$38,855.00 and Option A) Four Year Extended Compressor Warranty in the amount of \$375.00 and Option B) Top Skirt-@ Foot in the amount of \$1,150.00, payable in arrears and in accordance with Bid Proposal (Attachment B), which is attached and is hereby incorporated by reference. Payment for work under this Agreement shall be made per invoice for work completed. All work shall be in accordance with Bid No. S-1093-A and the Plans and Specifications (Attachment A), which are attached and are hereby incorporated by reference.
- 4.1 **General Conditions.** CONTRACTOR certifies and agrees that all the terms, conditions and obligations of the Contract Documents as hereinafter defined, the location of the job site, and the conditions under which the work is to be performed have been thoroughly reviewed, and enters into this Contract based upon CONTRACTOR'S investigation of all such matters and is in no way relying upon any opinions or representations of CITY. It is agreed that this Contract represents the entire agreement. It is further agreed that the Contract Documents including the Notice Inviting Bids, Special Instructions to Bidders, if

any, and Contractor's Proposal, are incorporated in this Contract by reference, with the same force and effect as if the same were set forth at length herein, and that CONTRACTOR and its subcontractors, if any, will be and are bound by any and all of said Contract Documents insofar as they relate in any part or in any way, directly or indirectly, to the work covered by this Contract. Contractor shall require and verify that all sub-contractors maintain insurance meeting the requirements herein.

"Project" as used herein defines the entire scope of the work covered by all the Contract Documents. Anything mentioned in the Specifications and not indicated in the Plans, or indicated in the Plans and not mentioned in the Specifications, shall be of like effect as if indicated and mentioned in both. In case of discrepancy in the Plans or Specifications, the matter shall be immediately submitted to City's Engineer, without whose decision CONTRACTOR shall not adjust said discrepancy save only at CONTRACTOR'S own risk and expense. The decision of the Engineer shall be final.

4.2 Materials and Labor. CONTRACTOR shall furnish, under the conditions expressed in the Plans and Specifications, at CONTRACTOR'S own expense, all labor and materials necessary, except such as are mentioned in the Specifications to be furnished by the CITY, to complete the project, in good workmanlike and substantial order. If CONTRACTOR fails to pay for labor or materials when due, CITY may settle such claims by making demand upon the surety to this Agreement. In the event of the failure of refusal of the surety to satisfy said claims, CITY may settle them directly and deduct the amount of payments from the Contract price and any amounts due to CONTRACTOR. In the event CITY receives a stop notice from any laborer or material supplier alleging non-payment by CONTRACTOR, CITY shall be entitled to deduct all of its costs and expenses incurred relating thereto, including but not limited to administrative and legal fees.

4.3 Project. The PROJECT is described as Furnish, Deliver and Install a Walk-In Refrigerator/Freezer at the Garden Grove Public Safety Building located at 11301 Acacia Parkway, Garden Grove, CA.

4.4 Plans and Specifications. The work to be done is described in a set of detailed Plans and Specifications entitled Furnish, Deliver and Install a Walk-In Refrigerator/Freezer at the Garden Grove Public Safety Building located at 11301 Acacia Parkway, Garden Grove, CA.

Said Plans and Specifications and any revisions, amendments or addenda thereto are attached hereto and incorporated herein as part of this Contract and referred to by reference. The work to be done must also be in accordance with the General Provisions, Standard Specifications and Standard Plans of City which are also incorporated herein and referred to by reference.

4.5 Time of Commencement and Completion. CONTRACTOR agrees to commence the Project with TEN (10) calendar days from the date set forth in the "Notice to Proceed" sent by City and shall diligently prosecute the work to completion within **NINETY (90)** calendar days from commencement of work excluding delays caused or authorized by the CITY as set forth in Sections 4.7, 4.8 and 4.9 hereof. The completion dates shall include any material delivery.

4.6 Time is of the Essence. Time is of the essence of this Contract. As required by the Contract Documents, CONTRACTOR shall prepare and obtain approval of all shop drawings, details and samples, and do all other things necessary and incidental to the prosecution of CONTRACTOR'S work in conformance with an approved construction progress schedule. CONTRACTOR shall coordinate the work covered by this Contract with that of all other contractors, subcontractors and of the CITY, in a manner that will facilitate the efficient completion of the entire work in accordance with Section 4.5 herein. CITY shall have complete control of the premises on which the work is to be performed and shall have the right to decide the time or order in which the various portions of the work shall be installed or the priority of the work of other subcontractors, and, in general, all matters representing the timely and orderly conduct of the work of CONTRACTOR on the premises..

4.7 Excusable Delays. CONTRACTOR shall be excused for any delay in the prosecution or completion of the Project caused by acts of God; inclement weather; damages caused by fire or other casualty for which CONTRACTOR is not responsible; and act, neglect or default of CITY; failure of CITY to make timely payments to CONTRACTOR; late delivery of materials required by this CONTRACT to be furnished by CITY; combined action of the workers in no way caused by or resulting from default or collusion on the part of CONTRACTOR; a lockout by CITY; or any other delays unforeseen by CONTRACTOR and beyond CONTRACTOR'S reasonable control.

City shall extend the time fixed in Section 4.5 herein for completion of the Project by the number of days CONTRACTOR has thus been delayed, provided that CONTRACTOR presents a written request to CITY for such time extension within fifteen (15) days of the commencement of such delay and CITY finds that the delay is justified. CITY'S decision will be conclusive on the parties to this Contract. Failure to file such request within the time allowed shall be deemed a waiver of the claim by CONTRACTOR.

No claims by CONTRACTOR for additional compensation or damages for delays will be allowed unless CONTRACTOR satisfies CITY that such delays were unavoidable and not the result of any action or inaction of CONTRACTOR and that CONTRACTOR took all available measures to mitigate such damages. Extensions of time and extra compensation as a result of incurring undisclosed utilities will be determined in accordance with Section 9-103A of the State of California Department of Transportation Standard Specifications. The CITY'S decision will be conclusive on all parties to this Contract.

4.8 Extra Work. The Contract price includes compensation for all work performed by CONTRACTOR, unless CONTRACTOR obtains a written change order signed by a designated representative of CITY specifying the exact nature of the extra work and the amount of extra compensation to be paid all as more particularly set forth in Section 4.9 hereof. CITY shall extend the time fixed in Section 4.5 for completion of the Project by the number of days reasonably required for CONTRACTOR to perform the extra work, as determined by CITY'S Engineer. The decision of the Engineer shall be final.

4.9 Changes in Project.

4.9.1 CITY may at any time, without notice to any surety, by written order designated or indicated to be a change order, make any change in the work within the general scope of the Contract, including but not limited to changes:

- a. in the Specifications (including drawings and designs);
- b. in the time, method or manner of performance of the work;
- c. in the City-furnished facilities, equipment, materials, services or site; or
- d. directing acceleration in the performance of the work.

4.9.2 A change order shall also be any other written order (including direction, instruction, interpretation or determination) from the CITY which causes any change, provided CONTRACTOR gives the CITY written notice stating the date, circumstances and source of the order and that CONTRACTOR regards the order as a change order.

4.9.3 Except as provided in this Section 4.9, no order, statement or conduct of the CITY or its representatives shall be treated as a change under this Section 9 or entitle CONTRACTOR to an equitable adjustment.

4.9.4 If any change under this Section 4.9 causes an increase or decrease in CONTRACTOR'S actual, direct cost or the time required to perform any part of the work under this Contract, whether or not changed by any order, the CITY shall make an equitable adjustment and modify the Contract in writing. Except for claims based on defective specifications, no claim for any change under paragraph (4.9.2) above shall be allowed for any costs incurred more than 20 days before the CONTRACTOR gives written notice as required in paragraph (4.9.2). In the case of defective specifications for which the CITY is responsible, the equitable adjustment shall include any increased direct cost CONTRACTOR reasonably incurred in attempting to comply with those defective specifications.

4.9.5 If CONTRACTOR intends to assert a claim for an equitable adjustment under this Section 4.9, it must, within thirty (30) days after receipt of a written change order under paragraph (4.9.1) or the furnishing of a written notice under paragraph (4.9.2), submit a written statement to the CITY setting forth the general nature and monetary extent of such claim. The CITY may extend the 30-day period. CONTRACTOR may include the statement of claim in the notice under paragraph (4.9.2) of this Section 4.9.

4.9.6 No claim by CONTRACTOR for an equitable adjustment shall be allowed if made after final payment under this Agreement.

4.9.7 CONTRACTOR hereby agrees to make any and all changes, furnish the materials and perform the work that CITY may require without nullifying this Contract. CONTRACTOR shall adhere strictly to the Plans and Specifications unless a change therefrom is authorized in writing by the CITY. Under no condition shall CONTRACTOR make any changes to the Project, either in additions or deduction, without the written order of the CITY and the CITY shall not pay for any extra charges made by CONTRACTOR that have not been agreed upon in advance in writing by the CITY. CONTRACTOR shall submit immediately to the CITY written copies of its firm's cost or credit proposal for change in the work. Disputed work shall be performed as ordered in writing by the CITY and the proper cost or credit breakdowns therefore shall be submitted without delay by CONTRACTOR to CITY.

4.10 Liquidated Damages for Delay. The parties agree that if the total work called for under this Contract, in all parts and requirements, is not completed within the time specified in Section 4.5 herein, plus the allowance made for delays or extensions authorized under Section 4.7, 4.8 and 4.9 herein, the CITY will sustain damage which would be extremely difficult and impractical to ascertain. The parties therefore agree that CONTRACTOR will pay to CITY the sum of two hundred and fifty dollars (\$250.00) per day for each and every calendar day during which completion of the Project is so delayed. CONTRACTOR agrees to pay such liquidated damages and further agrees that CITY may offset the amount of liquidated damages from any moneys due or that may become due CONTRACTOR under the Contract.

4.11 Contract Price and Method of Payment. CITY agrees to pay and the CONTRACTOR agrees to accept as full consideration for the faithful performance of this Contract, subject to any subsequent additions or deductions as provided in approved change orders, the sum as itemized in the bid proposal. Progress payments shall be made to the CONTRACTOR per month for each successive month as the work progresses. The CONTRACTOR shall be paid such sum as will bring the total payments received since the commencement of the work up to ninety percent (90%) of the value of the work completed, less all previous payments, provided that the CONTRACTOR submits the request for payment prior to the end of the day required to meet

the payment schedule. The CITY will retain ten percent (10%) of the amount of each such progress estimate and material cost until 30 days after the recordation of the Notice of Completion.

Payments shall be made on demands drawn in the manner required by law, accompanied by a certificate signed by the CITY'S Engineer, stating that the work for which payment is demanded has been performed in accordance with the terms of the Contract. Partial payments of the Contract price shall not be considered as an acceptance of any part of the work.

4.12 Substitution of Securities in Lieu of Retention of Funds. Pursuant to California Public Works Contract Code Section 22300, the CONTRACTOR will be entitled to post approved securities with the CITY or an approved financial institution in order to have the CITY release funds retained by the CITY to ensure performance of the Contract. CONTRACTOR shall be required to execute an addendum to this Contract together with escrow instructions and any other documents in order to effect this substitution.

4.13 Completion. CITY may require affidavits or certificates of payment and/or releases from any subcontractor, laborer or material supplier in connection with Stop Notices, which have been filed under the provisions of the statutes of the State of California.

4.14 Contractor's Employee Compensation.

4.14.1 General Prevailing Rate. CONTRACTOR shall comply with all applicable requirements of Division 2, Part 7, Chapter 1 of the California Labor Code and all applicable federal requirements respecting the payment of prevailing wages. If there is a difference between the minimum wage rates predetermined by the Secretary of Labor and the prevailing wage rates determined by the Director of the Department of Industrial Relations (DIR) for similar classifications of labor, the CONTRACTOR and its Sucontractors shall pay not less than the higher wage rate. The DIR will not accept lower State wage rates not specifically included in the Federal minimum wage determinations. This includes "helper" (or other classifications based on hours of experience) or any other classification not appearing in the Federal Wage determinations. Where Federal wage determinations do not contain the State wage rate determination otherwise available for use by the CONTRACTOR and Subcontractors, the CONTRACTOR and its Subcontractors shall pay not less than the Federal Minimum wage rate which most closely approximates the duties of the employees in question." CONTRACTOR shall be responsible for compliance with the most recent Federal Wage Requirements and may reference <http://www.wdol.gov/dba.aspx#0>.

4.14.2 Forfeiture for Violation. CONTRACTOR shall, as a penalty to the CITY, forfeit fifty dollars (\$50.00) for each calendar day or portion

thereof for each worker paid (either by the CONTRACTOR or any subcontractor under it) less than the prevailing rate of per diem wages as set by the Director of Industrial Relations, in accordance with Sections 1770-1780 of the California Labor Code for the work provided for in this Contract, all in accordance with Section 1775 of the Labor Code of the State of California.

4.14.3 Travel and Subsistence Pay. Section 1773.8 of the Labor Code of the State of California, regarding the payment of travel and subsistence payments, is applicable to this Contract and CONTRACTOR shall comply therewith.

4.14.4 Apprentices. Section 1777.5, 1777.6 and 1777.7 of the Labor Code of the State of California, regarding the employment of apprentices is applicable to this Contract and the CONTRACTOR shall comply therewith if the prime contract involves thirty thousand dollars (\$30,000.00) or more or twenty (20) working days, or more; or if contracts of specialty contractors not bidding for work through the general or prime contractor are two thousand dollars (\$2,000.00) or more for five (5) working days or more.

4.14.5 Workday. In the performance of this Contract, not more than eight (8) hours shall constitute a day's work, and CONTRACTOR shall not require more than eight (8) hours of labor in a day from any person employed by him thereunder except as provided in paragraph (4.14.2) above. CONTRACTOR shall conform to Article 3, Chapter 1, Part 7 (Sections 1810 et seq.) of the Labor Code of the State of California and shall forfeit to the CITY as a penalty, the sum of twenty-five dollars (\$25.00) for each worker employed in the execution of this Contract by CONTRACTOR or any subcontractor for each calendar day during which any worker is required or permitted to labor more than eight (8) hours in any one calendar day and forty (40) hours in any one week in violation of said Article. CONTRACTOR shall keep an accurate record showing the name and actual hours worked each calendar day and each calendar week by each worker employed by CONTRACTOR in connection with the Project.

4.14.6 Records of wages: Inspection. CONTRACTOR agrees to maintain accurate payroll records showing the name, address, social security number, work classification, straight-time and overtime hours worked each day and week, and the actual per diem wages paid to each journeyman, apprentice, worker or other employee employed by it in connection with the Project and agrees to require that each of its subcontractors does the same. All payroll records shall be certified as accurate by the applicable contractor or subcontractor or its agent have authority over such matters. CONTRACTOR further agrees that its payroll records and those of its subcontractors shall be available to the employee or employee's representative, the Division of Labor Standards

Enforcement, and the Division of Apprenticeship Standards and shall comply with all the provisions of Labor Code Section 1776, in general. ***Contractor shall require and verify that all sub-contractors maintain insurance meeting all the requirements herein.***

4.15 Surety Bonds. CONTRACTOR shall, upon entering into performance of this Agreement, furnish bonds in the amount of one hundred percent (100%) of the Contract price bid, to guarantee the faithful performance of the work, and the other in the amount of one hundred percent (100%) of the Contract price bid to guarantee payment of all claims for labor and materials furnished. This Contract shall not become effective until such bonds are supplied to and approved by the CITY. The Surety Company must have an AM Best rating of A- Class VII or better as approved by the City.

4.16 Insurance.

4.16.1 CONTRACTOR is also aware of the provisions of Section 3700 of the Labor Code, which requires every employer to be insured against liability for Workers' Compensation or undertake self-insurance with provisions of that Code before commencing the performance of the work of this Contract.

4.16.2 CONTRACTOR and all subcontractors will carry workers' compensation insurance for the protection of its employees during the progress of the work *and provide Employers Liability in an amount not less than \$1,000,000.* The insurer shall waive its rights of subrogation against the CITY, its officers, agents and employees and shall issue a certificate to the policy evidencing same.

4.16.3 CONTRACTOR shall at all times carry, for all operations hereunder policies of insurance for: (1) bodily injury, including death, and property damage liability insurance; (2) auto liability including mobile equipment if any, for bodily injury and property damage coverage; (3) and builders' all risk insurance. All insurance coverage shall be in amounts specified by CITY in Section 4.16.4 Insurance Requirements. CONTRACTOR shall provide evidence of insurance coverage by the issuance of a certificate of insurance and endorsements in a form prescribed by the CITY. Policies shall be underwritten by insurance companies satisfactory to CITY for all operations, subcontract work, contractual obligations, on-going, products and completed operations, all hired, leased, owned and non-owned vehicles and mobile equipment if any. Said insurance coverage obtained by the CONTRACTOR, excepting workers' compensation coverage, shall name the CITY, its Officers, Agents, Employees, Engineers, and Consultants for this Contract, and all public agencies from whom permits will be obtained and their Directors, Officers, Agents and Employees, as determined by the CITY, as additional insured on said policies.

For any claims related to this Agreement, CONTRACTOR'S insurance shall provide evidence that their coverage shall be primary insurance as respects CITY, its officers, officials, employees, agents, and volunteers. Any insurance or self-insurance maintained by the CITY, its officers, officials, employees, agents, or volunteers shall by excess of the CONTRACTOR'S insurance and shall not contribute with it.

4.16.4 Before CONTRACTOR performs any work at, or prepares or delivers materials to, the site of construction, CONTRACTOR shall furnish certificates of insurance and endorsements evidencing the foregoing insurance coverage and such certificates of insurance and endorsements shall provide the name and policy number of each insurance carrier and that an endorsement will provide the insurance is in force and will not be canceled without thirty (30) days written notice to the CITY. CONTRACTOR shall maintain all of the foregoing insurance coverage in force until the work under this Contract is satisfactorily and fully completed. The requirement for carrying the foregoing insurance shall not derogate from the provisions for indemnification of CITY by Contractor under Section 4.17 of this Contract. Notwithstanding nor diminishing the obligations of CONTRACTOR with respect to the foregoing, CONTRACTOR shall subscribe for and maintain in full force and effect during the life of this Contract, the following insurance in amounts not less than the amounts specified and issued by a company having a Best's Guide Rate of A-, Class VII or better (claims made and modified occurrence policies are not acceptable.) City reserves the right to modify these requirements including but no limited to limits based on the nature of the risk, prior experience, insurer, coverage or other special circumstances.

4.16.5 COMMENCEMENT OF WORK. CONTRACTOR shall not commence work under this Agreement until all certificates and endorsements have been received and approved by the CITY. All insurance required by this Agreement shall contain a Statement of Obligation on the part of the carrier to notify the CITY of any material change, cancellation, or termination at least thirty (30) days in advance and provide a waiver of subrogation in favor of the City *and provide a Waiver of Subrogation in favor of the City.*

4.16.6 INSURANCE AMOUNTS. CONTRACTOR shall maintain the following insurance for the duration of this Agreement:

- (a) Commercial general liability *in an amount not less than \$2,000,000 per occurrence, including products liability; (claims made and modified occurrence policies are not acceptable);* Insurance companies must be acceptable to CITY and have an AM Best's Guide Rating of A-, Class VII or better, as approved by the CITY.

- (b) Automobile liability for all autos in an amount not less than \$1,000,000 combined single limit; **(claims made and modified occurrence policies are not acceptable)**; Insurance companies must be acceptable to CITY and have an AM Best's Guide Rating of A-, Class VII or better, as approved by the CITY.
- (c) Excess liability coverage, *which follows form*, shall be provided for any underlying policy that does not meet the insurance requirements set forth herein **(claims made and modified occurrence policies are not acceptable)**. Insurance companies must be acceptable to CITY and have a Best's Guide Rating of A-Class VII or better, as approved by the CITY.
- (d) Property Insurance Installation Floater for all materials, equipment and material in the care, custody and control until equipment is successfully installed and tested. Contractor shall provide a safe and secure site for all materials, products and equipment until it is needed.
- (e) Transit Insurance from point to origin to delivery at City's designated site for the full value of the materials, products and/or equipment.

Contractor shall provide or arrange for transit insurance for physical damage of any nature whatsoever for material, products, equipment from point to origin to delivery to City's designated site. Title shall not pass to the City until products, material and/or equipment is received, inspected, and successfully installed and tested.

An Additional Insured Endorsement, **ongoing and completed operations, including products liability**, for the policy under section 4.16.6(a) shall designate CITY, its officers, officials, employees, agents, and volunteers as additional insureds for liability arising out of work or operations performed by or on behalf of the CONTRACTOR. CONTRACTOR shall provide to CITY proof of insurance and endorsement forms that conform to city's requirements, as approved by the CITY.

An Additional Insured Endorsement for the policy under section 4.16.6 (b) shall designate CITY, its officers, officials, employees, agents, and volunteers as additional insureds for automobiles owned, leased, hired, or borrowed by the CONTRACTOR. CONTRACTOR shall provide to CITY proof of insurance and endorsement forms that conform to CITY's requirements, as approved by the CITY.

An Additional Insured Endorsement for the policy under section 4.16.6 (c) shall designate CITY, its officers, officials, employees, agents, and volunteers as additional insureds under the excess liability policy. CONTRACTOR shall provide to CITY proof of insurance stating the excess liability policy follows form, additional insured endorsement forms, and the schedule of underlying policies with policy numbers, that conform to CITY's requirements, as approved by the CITY. Information for the excess policy only needs to be provided if the underlying policies do not meet the policy limits set forth herein.

For any claims related to this Agreement, CONTRACTOR's insurance coverage shall be primary insurance as respects CITY, its officers, officials, employees, agents, and volunteers. Any insurance or self-insurance maintained by the CITY, its officers, officials, employees, agents, or volunteers shall be in excess of the CONTRACTOR's insurance and shall not contribute with it.

4.17 Risk and Indemnification. All work covered by this Contract done at the site of the Project or in preparing or delivering materials to the site shall be at the risk of CONTRACTOR alone. CONTRACTOR agrees to save, indemnify and keep CITY, its Officers, Agents, Employees, Engineers, and Consultants for this Contract; and all public agencies from whom permits will be obtained and their directors, Officers, Agents and Employees harmless against any and all liability, claims, judgments, costs and demands, including demands arising from injuries or death of persons (CONTRACTOR'S employees included) and damage to property, arising directly or indirectly out of the obligations herein undertaken or out of the operations conducted by CONTRACTOR, save and except claims or litigation arising through the sole negligence or sole willful misconduct of CITY and will make good to reimburse CITY for any expenditures, including reasonable attorneys' fees CITY may incur by reason of such matters, and if requested by CITY, will defend any such suits at the sole cost and expense of CONTRACTOR.

4.18 Termination.

4.18.1 This Contract may be terminated in whole or in part in writing by the CITY for its convenience, provided that the CONTRACTOR is given (1) not less than ten (10) calendar days written notice (delivered by certified mail, return receipt requested) of intent to terminate, and (2) an opportunity for consultation with the terminating party prior to termination. Termination of contract shall conform to Section 8-1.11 of the State of California, Department of Transportation Standard Specifications.

4.18.2 If termination for default or convenience is effected by the CITY, an equitable adjustment in the price provided for in this Contract shall be made, but (1) no amount shall be allowed for anticipated profit on unperformed services or other work, and (2) any payment due to the

CONTRACTOR at the time of termination may be adjusted to cover any additional costs to the CITY because of the CONTRACTOR'S default. The equitable adjustment for any termination shall provide for payment to the CONTRACTOR for services rendered and expenses incurred in accordance with section 8-1.11 of the State of California, Department of Transportation Standard Specifications.

4.18.3 Upon receipt of a termination action under paragraph (4.18.1) or (4.18.2) above, the CONTRACTOR shall (1) promptly discontinue all affected work (unless the notice directs otherwise), and (2) deliver or otherwise make available to the CITY all data, drawings, specifications, reports, estimates, summaries and such other information and materials as may have been accumulated by the CONTRACTOR in performing this Contract whether completed or in process.

4.18.4 Upon termination under paragraphs (4.18.1) and (4.18.2) above, the CITY may take over the work and may award another party an agreement to complete the work under this Contract.

4.19 Warranty. The CONTRACTOR agrees to perform all work under this Contract in accordance with the CITY'S designs, drawings and specifications.

The CONTRACTOR guarantees for a period of one (1) year from the date of the notice of completion of the work that the completed work is free from all defects due to faulty materials, equipment or workmanship and that he shall promptly make whatever adjustments or corrections which may be necessary to cure any defects, including repairs or any damage to other parts of the system resulting from such defects. The CITY shall promptly give notice to the CONTRACTOR of observed defects. In the event that the CONTRACTOR fails to make adjustments, repairs, corrections or other work made necessary by such defects, the CITY may do so and charge the CONTRACTOR the cost incurred. The performance bond shall remain in full force and effect through the guarantee period.

The CONTRACTOR'S obligations under this clause are in addition to the CONTRACTOR'S other express or implied assurances provided under this Contract and in no way diminish any other rights that the CITY may have against the CONTRACTOR for faulty materials, equipment or work.

4.20 Attorneys' Fees. If any action at law or in equity is necessary to enforce or interpret the terms of this Contract, the prevailing party shall be entitled to reasonable attorneys' fees, costs and necessary disbursements in addition to any other relief to which it may be entitled. If any action is brought against the CONTRACTOR or any subcontractor to enforce a Stop Notice or Notice to Withhold, which named the CITY as a party to said action, the CITY shall be entitled to reasonable attorneys' fees, costs and necessary disbursements arising out of the defense or such action by the CITY. The CITY shall be

entitled to deduct its costs for any Stop Notice filed, whether court action is involved or not.

4.21 Notices. Any notice required or permitted under this Contract may be given by ordinary mail at the address set forth below. Any party whose address changes shall notify the other party in writing.

To CITY: City of Garden Grove
 City Attorney
 11222 Acacia Parkway
 Garden Grove, California 92840

To CONTRACTOR: Jorge Flores
 Attention: Jorge Flores, Sole Owner
 P.O. Box 5212
 Glendale, CA 91221-1094

(Agreement Signature Block On Next Page)

IN WITNESS THEREOF, these parties have executed this Project Agreement on the day and year shown below.

Date: _____

"CITY"
CITY OF GARDEN GROVE

By: _____
City Manager

ATTEST:

City Clerk

Date: _____

"CONTRACTOR"
Jorge Flores

Contractor's State Lic. No. 680721

Expiration Date: 11/30/2013

By: Jorge A. Flores

Title: OWNER

Date: 7/23/2012

Tax ID No. 568-84-6247

If CONTRACTOR is a corporation, a Corporate Resolution and/or Corporate Seal is required. If a partnership, Statement of Partnership must be submitted to the CITY.

APPROVED AS TO FORM:



Garden Grove City Attorney

ATTACHMENT "A"
IFB NO. S-1093-A

Furnish, Deliver and Install a Walk-In Refrigerator/Freezer at the Garden Grove Public Safety Building located at 11301 Acacia Parkway, Garden Grove, CA.

PROJECT SCOPE:

The Garden Grove Police Department is soliciting bids for the construction of a 16' x 20' x 8', walk-in refrigerator/freezer unit. The refrigerator/freezer unit will need to be assembled in a single-story, block wall building that is located adjacent to the public safety building. The refrigerator/freezer unit must be suitable for the long-term storage of perishable items.

A mandatory site inspection will be held to allow prospective Contractors to familiarize themselves with the site and all conditions that may affect the performance and cost of the Contractor. Contractor must deliver and install a fully functional and operational unit in order for the project to be deemed complete by the City.

PROJECT REQUIREMENTS:

- **Freezer:** Approximate dimensions are 11' wide X 16' deep X 8" high. Please come prepared to the site inspection to take your own measurements, as the bidders are responsible for their own measurements. Dimensions are based on OD and not ID.
- **Cooler:** Approximate dimensions are 8" wide X 6" deep X 8" high. Please come prepared to the site inspection to take your own measurements, as the bidders are responsible for their own measurements. Dimensions are based on OD and not ID.
- Temperature is to be between 0-15 degrees
- Could use a combination set up
- Stucco embossed galvanized steel finish inside and out
- Flooring cooler and/or freezer:
 - Is to be raised
 - Single Ramp
 - Non-Skid rubberized flooring
- Door/s with heated frames are to be standard for the freezer and cooler
36" X 78"

- View Window-Qty (1) One to be standard size (18" X 18")
- Proper Drainage
- Electric Defrosting
- Lighting-NSF approved fixtures
- Lock is to be a simple padlock
- **Shelving:** Interior shelving shall be NSF approved adjustable flat solid shelf type with galvanized finish. Each shelf unit is to have 5 shelves. Shelving is to be assembled and installed with shelf spacing as directed. Appropriate seismic restraints are to be included. Shelving sizes and quantities are to be as follows:
 - 72"H X 48"W X 24"D, 10 Shelves (2 units)
 - 72"H X 60"W X 24"D, 10 Shelves (7 units)
 - 72"H X 60"W X 24"D, 4 Shelves (2 units)
 - 72"H X 36"W X 24"D, 10 Shelves (3 units)
 - 72"H X 72"W X 24"D, 10 Shelves (1 unit)
- Alarm activated audio and visual thermostat/s
- Weekend battery back-up and auto dialer
- Fire Protection-This will be waived by the City.

INSTALLATION:

Complete installation to include: all labor and miscellaneous materials to complete construction, delivery and set-up of all equipment, including to the roof, roof platform, roof penetration, building alteration and/or core drilling and finished electrical connections. The City will take care of removing the two existing light panels on the ceiling and will perform any work needed to conceal any holes after the removal.

REMOVAL AND DISPOSAL OF EXISTING EQUIPMENT: Total bid price is to include the disassembly, haul away and proper disposal of the existing refrigeration equipment. Contractor is also responsible to work with City staff to coordinate the change over from the old equipment to the new equipment.

WARRANTY:

Bid proposal to include information on the warranty of the product including length of the warranty, parts and labor, and exclusions to the policy. If an extended warranty is available please include the cost on the Bid Proposal (ATTACHMENT "B"). Adding the extended warranty to the contract will be an additional option, which will be at the sole option of the City based on available funds. This Option will not be used to determine the lowest responsible bidder.

EQUIPMENT:

Any equipment needed/rented for this project shall be at the expense of the Contractor and included in the bid proposal.

PERMITS/LICENSES:

- Prospective Contractors must possess a **Class B** General Builder's License AND/OR a State of California Contract License Classification **C-38 Refrigeration** License to perform the work specified in herein.
- Contractor shall apply for and obtain all required City building and construction permits prior to the start of the work. All required permits are at the expense of the Contractor.
- The successful bidder is required to obtain a City of Garden Grove business license before the work can commence.

DELIVERY/FREIGHT COSTS: Delivery and Freight costs *are to be included* in the cost of the bid.

ELECTRICAL REQUIREMENTS: On Page 32 is a drawing of the current AT&T Phone Room in Jail Main P.D. Building. Once the old units are removed, it our understanding that the current set up should be sufficient.

AT&T Phone Room in Jail Main P.D. Building

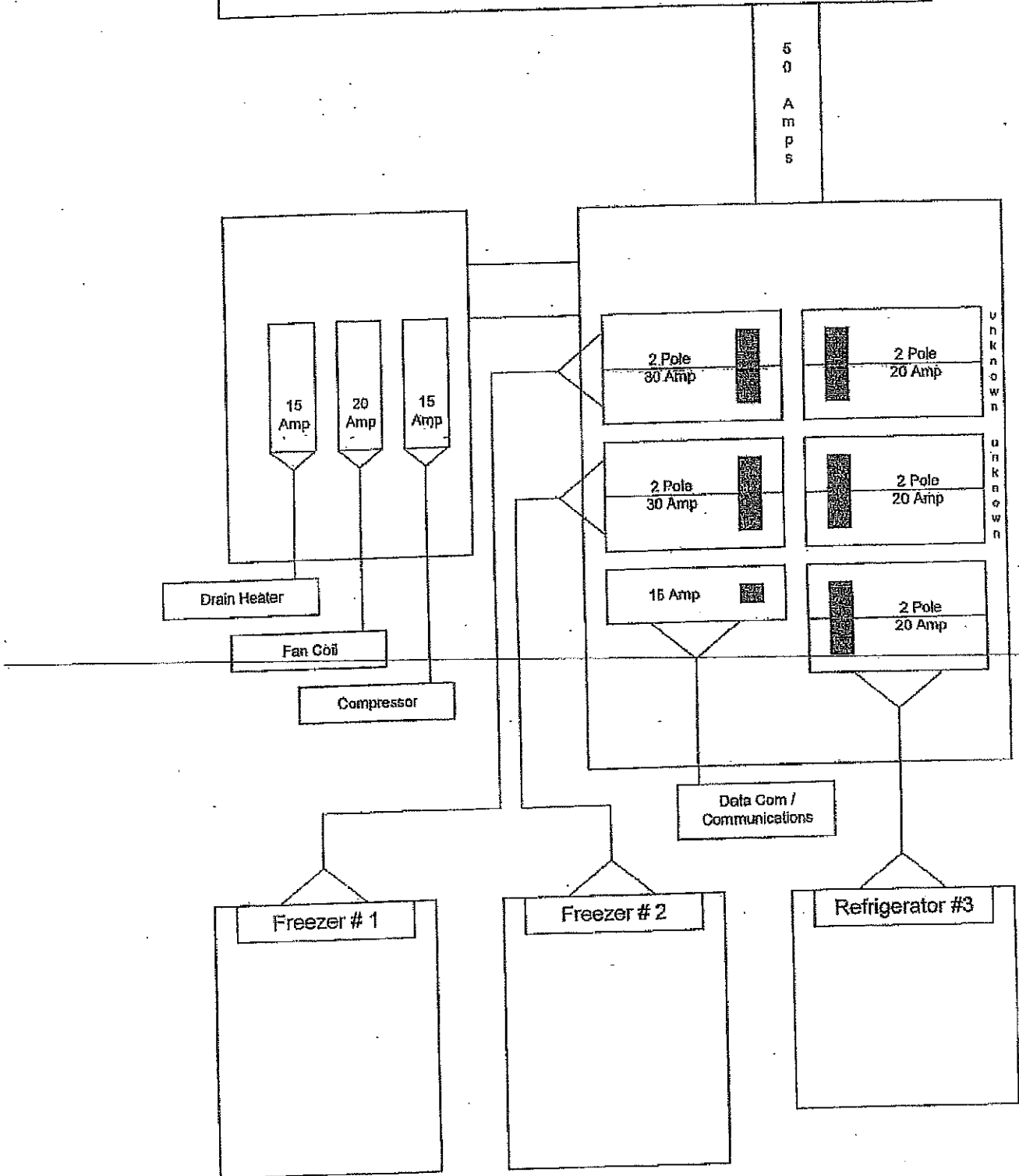

"Attachment "A"

ADDENDUM No. 1

Covering

CHANGE IN SPECIFICATIONS AND/OR PLANS

Date Issued: June 14, 2012

Date Effective: June 14, 2012

ITB No. S-1093-A

Contract: Furnish and Install a Walk-In Refrigerator/Freezer at the Garden Grove Public Safety Building located at 11301 Acacia Parkway, Garden Grove, CA.

INTENT

1. This addendum is issued prior to receipt of bids to provide for modifications in plans and/or specifications. Acknowledgment of this addendum shall be made and cost for work included in proposer's submittal.
2. Proposal (Attachment B) has been revised to include the optional top skirt: A revised copy of the Proposal (Revision B), which is attached, must be submitted in place of the original pages which were included in the bid document.
3. Pages 29-32 Scope of Work has been revised as follows:
 - **Freezer:** Approximate dimensions are **11' wide X 16' deep X 8'** high. Please come prepared to the site inspection to take your own measurements, as the bidders are responsible for their own measurements. Dimensions are based on OD and not ID.
 - **Cooler:** Approximate dimensions are **8' wide X 6' deep X 8'** high. Please come prepared to the site inspection to take your own measurements, as the bidders are responsible for their own measurements. Dimensions are based on OD and not ID.
 - **Door:** Door is to swing out and to be left-hinged
 - **Drainage:** Drainage is to be set up with a condenser pump as seen in the existing freezer/fridge unit.
 - **Ramp:** Ramp is to be an indoor ramp

- **Optional Top Skirt:** Please provide a quote for a 2-foot top skirt. This is an optional item and will not be used to determine the lowest responsible bidder. The City reserves the right to accept or reject this option based on available funding.
4. The contractor is hereby notified that Addendum No. 1 must be acknowledged and submitted as part of the bid. Failure to do so could result in the City designating said bid as "Non Responsive". All other terms and conditions of the BID shall remain the same

Issued by:

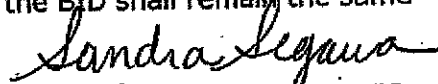

Sandra Segawa, C.P.M., CPPB
Purchasing Agent

"Attachment A"

ADDENDUM No. 2

Covering

CHANGE IN SPECIFICATIONS AND/OR PLANS

Date Issued: June 19, 2012

Date Effective: June 19, 2012

ITB No. S-1093-A

Contract: Furnish and Install a Walk-In Refrigerator/Freezer at the Garden Grove Public Safety Building located at 11301 Acacia Parkway, Garden Grove, CA.

INTENT

1. This addendum is issued prior to receipt of bids to provide for modifications in plans and/or specifications. Acknowledgment of this addendum shall be made and cost for work included in proposer's submittal.

2. Questions Received regarding the bid specification. These revisions are to be reflected in your bid pricing and replace any previous bid specifications.

a. **Question:** Just wanted to confirm that the depth of the freezer is 16" deep.

Answer: Please see freezer dimensions below.

Freezer: Approximate dimensions are **11' wide X 16' deep X 8' high**. Please come prepared to the site inspection to take your own measurements, as the bidders are responsible for their own measurements. *Dimensions are based on OD and not ID.*

b. **Question:** Addendum No. 1 states that the Drainage is to be set up with a condensate pump as seen in the freezer/fridge unit, what they have in the existing unit is an. There is a difference between the two, the condensate pump, pumps the water to the sink, the electric condensate pan heater, has water go into the pan and evaporates.

Answer: Drainage style is to be the electric condensate pan heater as seen in the existing freezer/fridge unit.

3. The contractor is hereby notified that Addenda No. 1 and 2 must be acknowledged and submitted as part of the bid. Failure to do so could result in the City designating said bid as "Non Responsive". All other terms and conditions of the BID shall remain the same

Issued by:

Sandra Segawa, C.P.M., CPPB
Purchasing Agent

"Attachment A"

ADDENDUM No. 3

Covering

CHANGE IN SPECIFICATIONS AND/OR PLANS

Date Issued: June 27, 2012

Date Effective: June 27, 2012

ITB No. S-1093-A

Contract: Furnish and Install a Walk-In Refrigerator/Freezer at the Garden Grove Public Safety Building located at 11301 Acacia Parkway, Garden Grove, CA.

INTENT

1. This addendum is issued prior to receipt of bids to provide for modifications in plans and/or specifications. Acknowledgment of this addendum shall be made and cost for work included in proposer's submittal.

2. Question Received regarding the bid specification. These revisions are to be reflected in your bid pricing and replace any previous bid specifications.

a. **Question:** We have a quick question in terms of the shelving units that are requested. In the original bid document there is a statement that each shelving unit is to have 5 shelves each. However in the quantities section there are shelving units with more than 5 shelves and some with 4. I wanted to verify the quantities for the shelves.

Answer: Please note the changes to the shelving requirements, which are different than the bid document states.

72"H X 48"W X 24"D, 6 Shelves (2 units)

72"H X 60"W X 24"D, 10 Shelves (2 units)

72"H X 60"W X 24"D, 4 Shelves (8 units)

72"H X 36"W X 24"D, 4 Shelves (4 units)

3. The contractor is hereby notified that Addenda No. 1, 2 and 3 must be acknowledged and submitted as part of the bid. Failure to do so could result in the City designating said bid as "Non Responsive". All other terms and conditions of the BID shall remain the same

Issued by:

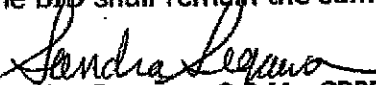
Sandra Segawa, C.P.M., CPPB
Purchasing Agent

ATTACHMENT "B"

SECTION 2 - PROPOSAL

THE HONORABLE MAYOR AND CITY COUNCIL
CITY OF GARDEN GROVE
11222 ACACIA PARKWAY
GARDEN GROVE, CALIFORNIA 92840

To: THE HONORABLE MAYOR AND CITY COUNCIL

The undersigned having carefully examined the Specifications to: Furnish, Deliver, and Install a Walk-In Refrigerator/Freezer at the Garden Grove Public Safety Building located at 11301 Acacia Parkway, Garden Grove, CA. Lead-time for this service is critical. CONTRACTOR agrees to commence the Project with TEN (10) calendar days from the date set forth in the "Notice to Proceed"

HEREBY PROPOSE to furnish all labor, materials, equipment and transportation, and do all the work required to complete work in accordance with the Plans and Specifications for the sum of:

BID PROPOSAL			
Item	Address	Description	Total Cost
1.	11301 Acacia Parkway, Garden Grove, CA 92840	Furnish, Deliver and Install a walk-in evidence freezer/cooler at the Garden Grove Public Safety Building In compliance with specifications and general provisions.	\$ 38,855.00
PARTIAL BIDS WILL NOT BE ACCEPTED! TOTAL COST of Project In Written Words THIRTY EIGHT THOUSAND EIGHT HUNDRED FIFTY FIVE DOLLARS Lump Sum (Including all applicable sales tax)			
The above bid price includes all applicable taxes for the pricing proposed in this submittal. Note: In case of discrepancy between the words and figures, the words prevail.			

Optional Item A: Extended Warranty: This Option will not be used to determine the lowest responsible bidder. At the sole option of the City, this Option may be added to the TOTAL COST of the project above and is subject to availability of funds. If Several Options are available you may list them all or attach additional sheets if necessary.

Item	Warranty Term	Warranty: Please state what is included and excluded	Total Cost
1.	4 YEAR EXTENDED	COMPRESSOR COST ONLY	\$ 375.00
2.			\$

Optional Item B: Top Skirt (2 foot): This Option will not be used to determine the lowest responsible bidder. At the sole option of the City, this Option may be added to the TOTAL COST of the project above and is subject to availability of funds.

\$ 1,150.00

It is understood and agreed that:

- (a) No verbal agreement or conversation with any officer, agent or employee of CITY, either before or after the execution of the Agreement shall affect or modify any of the terms or obligations of this Proposal.
- (b) CITY will not be responsible for any errors or omissions on the part of the undersigned in making up his bid, nor will bidders be released on account of errors.
- (c) The undersigned hereby certifies that this Proposal is genuine and is not sham or collusive, or made in the interest or in behalf of any person not herein named, and that the undersigned has not directly or indirectly induced or solicited any other bidder to put in a sham bid, or any other person, firm or corporation to refrain from bidding, and that the undersigned has not in any manner sought, by collusion, to secure for himself an advantage over any other bidder.
- (d) The Bidder acknowledges receipt of amendments to the Solicitation and related documents numbered and dated:

<u>Amendment No.</u>	<u>Date</u>
1	6/14/2012
2	6/19/2012
3	6/27/2012

(e) undersigned has not in any manner sought, by collusion, to secure for himself an advantage over any other bidder.

Check below where appropriate:

Partnership: That _____ are partners,
doing _____ (Names of all Partners)

business under the firm name of _____ and
that the co-partnership makes the accompanying proposal.

Corporation: That _____ of
_____ makes (President or Secretary) (Name of
Corporation)
the accompanying proposal.

Individual: That JORGE FLORES is the bidder and makes the
(Name of Individual)
accompanying proposal

Date: 6/27/2012 A DESIGN REFRIGRATION
Company Name
918 JUSTIN AVE, SUITE C
Address
GLENDARE CA 91201
City - State - Zip
(914) 625-2005
Telephone
C-34-680721
Calif. Contractors Lic. No.
JORGE FLORES
Bidder's Name (Please Print)
Jorge A. Flores
Authorized Signature